

Warranty Information

Proof of purchase will be required.

The guarantee does not cover faults or damage caused by incorrect installation and/or maintenance, ordinary wear and tear, water composition, etc.

*Please see www.deva-uk for full terms and conditions of warranty

Cleaning

Your product has a high-quality finish and should be treated with care to preserve the visible surfaces. Never use abrasives or abrasive cleaning agents to clean this product clean regularly with contamination free warm water and a damp soft cloth. Do not use products containing chlorine bleach or hydrochloric acid as these can damage the product.

We have a policy of continuous improvement and reserve the right to change specifications without notice.

METHVEN UK LIMITED

METHVEN EXPERIENCE CENTRE

3/3A STONE CROSS COURT

YEW TREE WAY GOLBORNE

WARRINGTON

WA3 3JD

UNITED KINGDOM

INST-MTBBB, MTBBK, MTBBN,
MTBCP & MTBGM -V2

12-2025

TEL: 0800 195 1602

FAX: 0844 406 8690

EMAIL: customer@uk.methven.com

www.deva-uk.com

www.methven.com

Motu Basin Mixer

MTBBB, MTBBK, MTBBN, MTBCP & MTBGM Installation Guide

Technical Specification

Working Pressure:

Min: 1.0 Bar

Max: 5.0 Bar

Operating Temperature:

Hot: 65°C

Cold: 5°C

Inlet Connections:

½" BSP

Features:

- Ceramic Cartridge For Smooth Operation
- Fitted With a 4 l/min Flow Regulator
- Slim Stream Aerator With Directional Swivel
- Includes Press Top Waste
- 20 Year Warranty on Chrome Finish
- 5 Year Warranty on Non-chrome Outer Finishes



METHVEN
www.methven.com EST 1886

Contents

Congratulations on your purchase of your new Methven Basin Mixer. Our fitting instructions have been created with you in mind to provide you with all the information you require and, if you need any further help, please don't hesitate to contact our customer care team on 0800 195 1602.

General Safety Information 3

Line Drawing 3

Product Breakdown 4

Product Breakdown 4

Installation Requirements 6

Installation 6

Troubleshooting 7

Warranty Information 8

Cleaning 8

Troubleshooting

Symptom	Cause(s)	Resolution
No flow or low flow rate	Partially closed isolation valve	Open isolation valve
	Instantaneous water heater cycles on and off as flow rate or pressure is too low	Increase water flow rate or pressure through system.
	Air lock or partial blockage in the supply pipework or hoses	Flush through pipework to ensure removal of debris and any airlocks.
	Hot or cold water being drawn off elsewhere causing pressure changes or instantaneous boiler temperature changes.	Try not to use other water outlets when using the mixer
Water dripping from the mixer	This is normal for a short time after using the mixer	This is due to residual water tension, the build up of water in the tap body.
	If water continues to drip, possible issue with the flow control cartridge.	Please contact our customer care team.
Mixer does not turn on	Closed isolation valve	Open isolation valve
	Mains water supply turned off	Turn on mains water supply

Installation Requirements

Before commencing installation of the new product, ensure that the system has been flushed to remove any debris, which could cause damage to the valves and invalidate the warranty.

Installation

- 1, Fit the base ring onto the bottom of the tap body the raised edge of the base ring sits inside the lip on the base of the tap with the rubber washer facing the basin.
- 2, Insert the fixing bolt into the bottom of the tap, with the slot facing out and using a flat bladed screwdriver tighten this up.
- 3, Screw the flexible tails into the bottom of the tap, by hand, until tight. Do not use PTFE tape, or similar, on the threads.
- 4, Feed the tails and fixing bolt into the hole in the basin, ensuring that the base ring and rubber washer are seated correctly and fully covering the hole.
- 5, From the underside of the basin feed the rubber horseshoe shaped washer over the fixing bolt followed by the metal one. Place the nut over the fixing bolt and tighten until the tap is fixed on the basin. Do not over tighten.
- 6, Connect the hot and cold feeds to the water supply.
- 7, Reinstate the water supply and test for leaks.

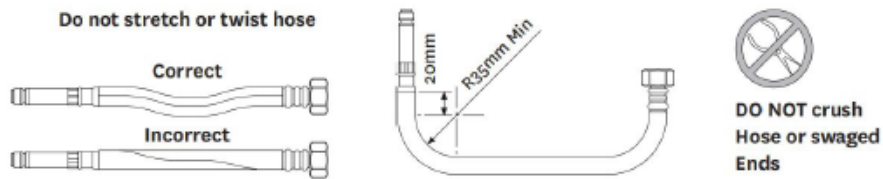

Please keep these instructions for future reference and request of replacement parts

General Safety Information

Please read all of the instructions before installation.

Methven recommends this product is installed by a competent person in compliance with all relevant regional regulations.

Remove all packaging and check the components for damage before starting installation.

This product **must** not be modified in any way as this will invalidate the guarantee.

It is the responsibility of the installer to ensure a waterproof seal is achieved, after installation all connections must be checked for leaks.

All outlets used primarily for personal hygiene shall deliver water at a safe temperature as per regional regulations.

Line Drawing

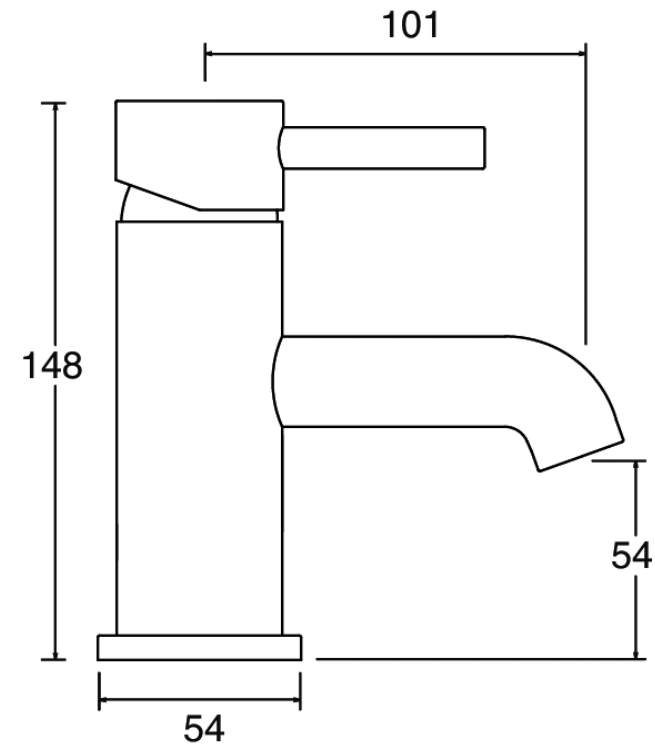

Product Breakdown

Check All components are present prior to starting installation.

Part Number	Description
1	Handle Lever
2	Screw
3	Handle Body
4	Plastic Cover
5	Cartridge Nut
6	Cartridge
7	Body
8	Base Plate
9	Washer
10	Flexi tails
11	Fixing Kit
12	Connector
13	O-Ring
14	Screw
15	Spout
16	Aerator
17	Press Top Waste

